

Introduction to Simulink and Digital Representations of Signals and Sampling

Class Notes

Sampling

When we examine continuous process using digital modeling techniques, we are essentially looking at the process by examining it at discrete intervals. For example, a continuous process might generate a signal:

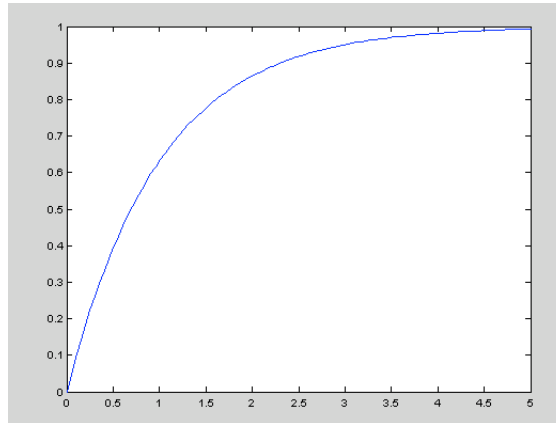

This figure was generated using the MATLAB code:

```
>> t=linspace(0,5,100);  
>> x=1-exp(-t);  
>> plot(t,x)
```

However, within a computer that process is examined at discrete intervals. This is the equivalent of sampling the above signal as shown below:

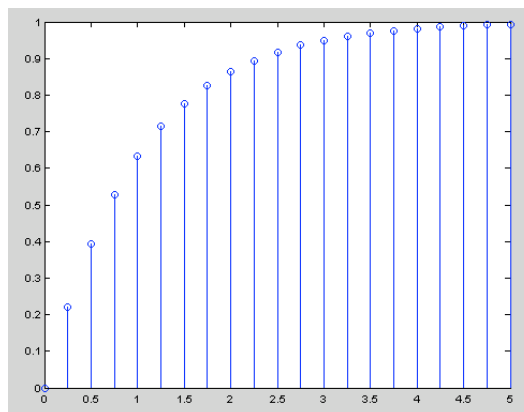

This figure was generated using the MATLAB code:

```
>> t=linspace(0,5,20);
>> x=1-exp(-t);
>> stem (t,x)
```

It should be noted that when the data is acquired in a digital format, that only a discrete number of possible values exist for any measurement

8 bit	2^8	= 256 possible values (0 to 255)	
10 bit	2^{10}	= 1024 possible values (0 to 1023)	
12 bit	2^{12}	= 4096 possible values (0 to 4095) ←	in practice this is almost always more than enough data
16 bit	2^{16}	= 65,536 possible values (0 to 65,535)	

Note that 1/2 values do not exist. Digitized signal can have a value of 4 or 5, but not 4 1/2.

Processes that change continuously as a function of time are known as dynamic processes. There are 2 classes of dynamic processes

Deterministic Processes

Deterministic Processes are those that have “known” characteristics and can be described as a mathematical function. Most signals of interest fall into this class. The techniques used to describe the signals are based on the nature of the signals.

Transient processes are aperiodic and decay/approach to a constant value after a finite amount of time. The output shown above is the result of a transient process.

Periodic processes are repeat themselves in a continuous repeating pattern. Periodic processes may be expressed in terms of a Fourier Series:

$$x(t) = \frac{a_0}{2} + \sum_{n=1}^{\infty} a_n \cos(n\omega t) + b_n \sin(n\omega t)$$

where: a, b = constants
 n = integer defining the order of the harmonic
 ω = fundamental radian frequency

For us, this equation has a number of important implications

1. Very complex waveforms are in fact described as the sum of a series of sines and cosines
2. The agreement between an arbitrary periodic function and the Fourier series increases as more terms are added.
3. Signals can be analyzed and recreated by handling them in the frequency domain.
4. The mirror image of this is that, when a signal is output using a D/A converter, it is output in discrete steps and will have many more frequencies than when acquired.

A description of a periodic function is typically based on the frequencies of the components that are added together to create the function. Processes with a finite bandwidth of f -Hertz can be described by examining the time signals at instants separated by $T = 1/2f$ seconds

That is: a signal must be sampled at a rate at least twice as high as the highest frequency in the spectrum. For example, under ideal conditions, the left-hand signal can be recreated from the right-hand signal

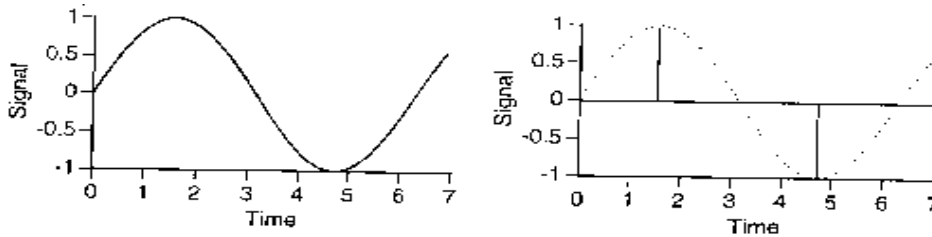

In practice, this is a lower limit to the sampling frequency and will only yield satisfactory results if the sampling alignment a perfect match, as shown above. For example, if the sampling is not an exact match (a very likely condition in an unknown signal) you could see a much reduced signal amplitude. In the case of the rightmost signal, the amplitude has been reduced to the point where signal appears to be a straight line.

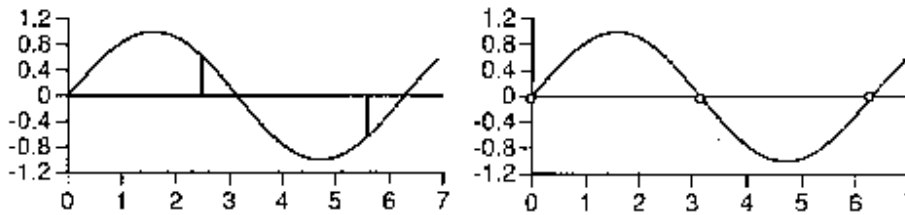

One needs to note that higher order frequencies almost always exist and the highest order frequency is usually above the highest order frequency of interest. Under these conditions “aliasing” becomes a problem

When a given frequency is sampled at too low a rate, it can appear as a totally different, lower, frequency at the output of the sampling device. When the higher frequency sample (period = 2π) shown below is sampled with a period of 6.2 the lower frequency sinusoid is the apparent frequency.

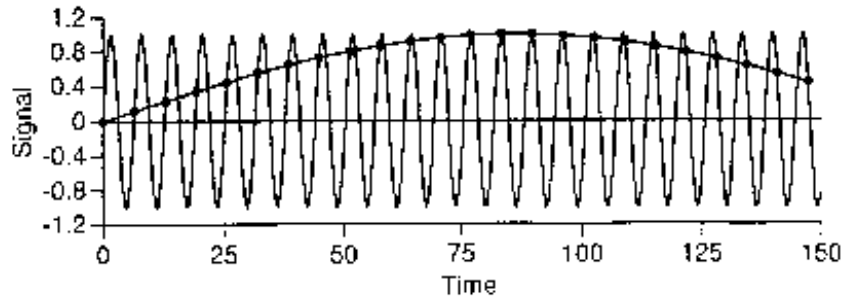

Random Processes

Random Processes are processes whose behavior is highly unpredictable as a function of time. There are several classes of random processes that are relevant to biological modeling. There are *random processes* and *chaotic processes*. We will discuss chaotic processes later. Random processes usually appear as external inputs to a process.

Example: A Temperature Model

For example, the temperature might be described as an annual cycle with an overlay of a daily cycle. However, there is also a random element that overlays both of the process.

Thus, a Simulink model for temperature might appear as shown below:

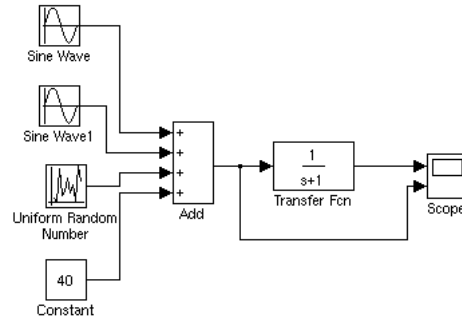

In this model, the upper sine wave (the annual cycle) has the following characteristics:

$$\begin{aligned} \text{Amplitude} &= 60 \text{ (120}^\circ\text{F total range in temperature/year)} \\ \text{Frequency} &= 2\pi/365 \text{ radians per day} \end{aligned}$$

In this model, the lower sine wave (the daily cycle) has the following characteristics:

$$\begin{aligned} \text{Amplitude} &= 15 \text{ (30}^\circ\text{F range in temperature per day)} \\ \text{Frequency} &= 2\pi \text{ radians per day} \end{aligned}$$

The random component of the signal was uniformly distributed between -15 and +15.

The constant offset is the annual average temperature

These four inputs are then added using a summing junction and fed into the transfer function.

The transfer function is a low pass filter added to “remove the noise” from the model. (In some ways a silly addition, since we’re adding noise to be removed) It is a “first order low pass filter” with a time constant, τ , of 1. This might be the process under development to identify the best time constant for cleaning up the signal.

The output from the model (shown in the scope) was:

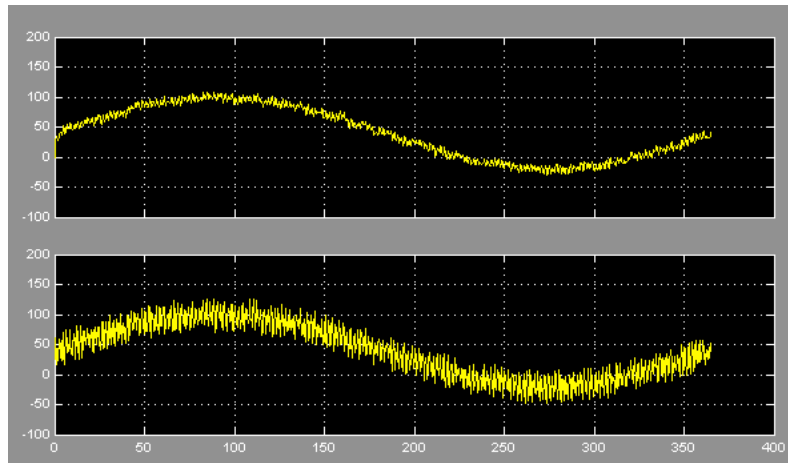

The outputs shown on the scope correspond to the inputs. Thus, the upper curve is the filtered signal and the lower curve is the raw signal.

Aliasing

One needs to note that higher order frequencies almost always exist and the highest order frequency is usually above the highest order frequency of interest. Under these conditions “aliasing” becomes a problem.

When a given frequency is sampled at too low a rate, it can appear as a totally different, lower, frequency at the output of the sampling device. When the higher frequency sample (period = 2π) shown below is sampled with a period of 6.2 the lower frequency sinusoid is the apparent frequency.

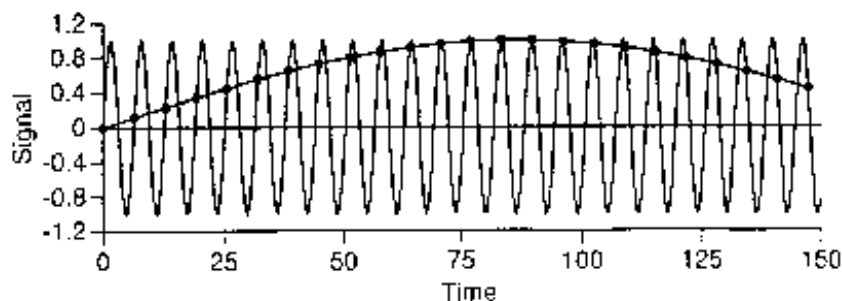

Sampling Frequency

Another problem with examining a process at too low a frequency is that you may miss the trait that you are looking to find or that you are trying to model. For example, if one is looking at an EKG, such as the one shown below:

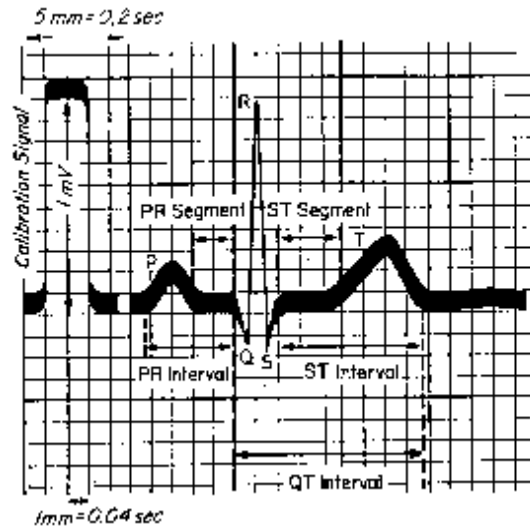

Then the effect of sampling rate (200, 1000, and 10,000 Hz) is:

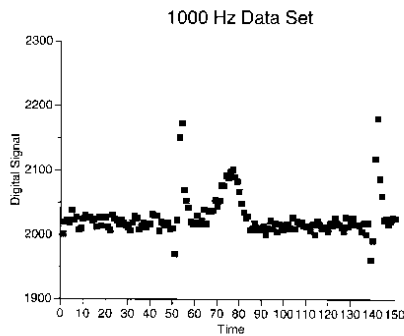
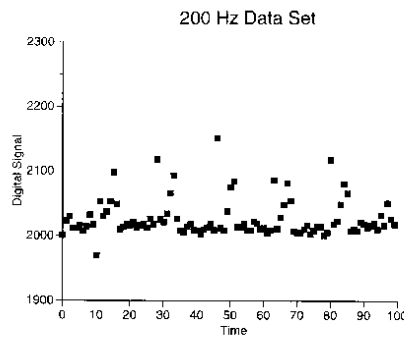

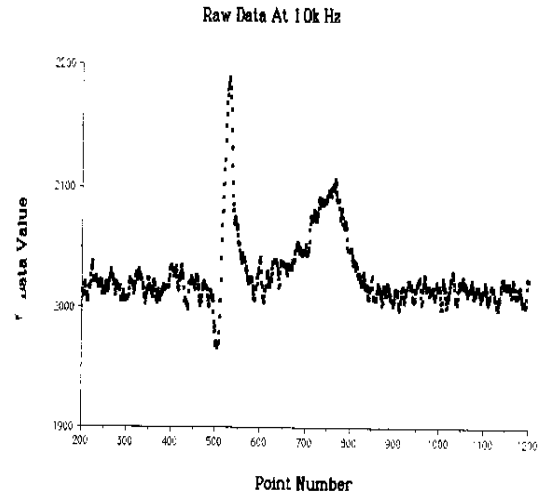

Depending on the feature that is relevant, you will want to examine the process at various frequencies. If the goal is to determine the heart rate, the QRS complex is clear at 1000 Hz. However, if the goal is to identify a defect in the EKG, a 10,000 Hz sampling frequency may be adequate. Remember that, typically, the goal of building a model of a complex input is for use in examining the effect of a designed process.